

Content Indexing

PDF
Number of pages

01.Index	-----1
02.Change List	-----2
03.Block Diagram	-----3
04.Power tree-RK805-1	-----4
05.System Power-PMIC RK805-1	-----5
06.RK3328 Power	-----6
07.RK3328 OSC/PLL/OTP/SARADC	-----7
08.RK3328 DDR Controler	-----8
09.RK3328 eMMC Controler/TF/SPI	-----9
10.RK3328 USB2 PHY/USB3 PHY	-----10
11.RK3328 SDIO/UART/I2C/I2S/IR	-----11
12.RK3328 HDMI PHY	-----12
13.RK3328 AV Interface	-----13
14.RK3328 FEPHY	-----14
15.RAM DDR4 2x16bit	-----15
16.DC_IN/RECOVER	-----16
17.TF/SD Card/AT18	-----17
18.Flash-eMMC	-----18
19.USB Port	-----19
20.HDMI OUT Port	-----20
21.AV OUT Port	-----21
22.10/100M-Embed PHY	-----22
23.WIFI+BT_1T1R	-----23
24.Connector	-----24

Note:

Component parameter description

1. DNP stands for component not mounted temporarily

2. If Value or option is DNP, which means the area is reserved without being mounted

 Firefly		www.t-firefly.com	
Title: <Title>			
File: <Doc>		REV: <Revcode>	
Create Date: Thursday, March 09, 2017	Page Num: 1		
Modify Date: Monday, September 25, 2017	Page Total: 24		

Version	Date	Author	Change Note	Approved
V00	20170925	LZZ	First edictor	



www.t-firefly.com

Title: <Title>		REV: <Revcode>
File: <Doc>		
Create Date: Thursday, March 09, 2017	Page Num: 2	
Modify Date: Monday, September 25, 2017	Page Total: 24	

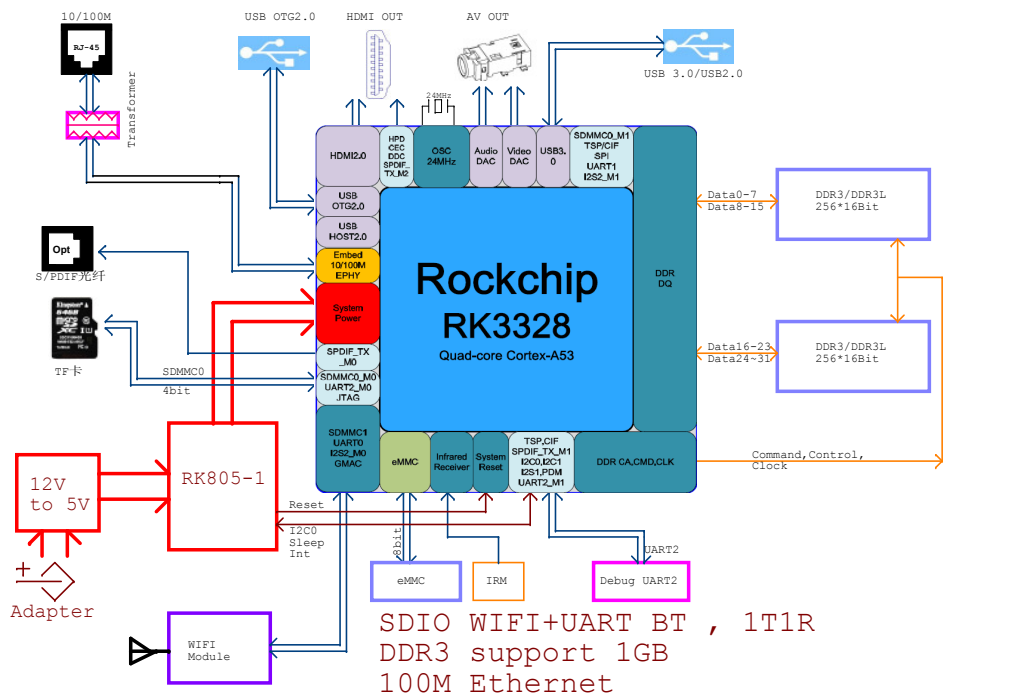

Default config

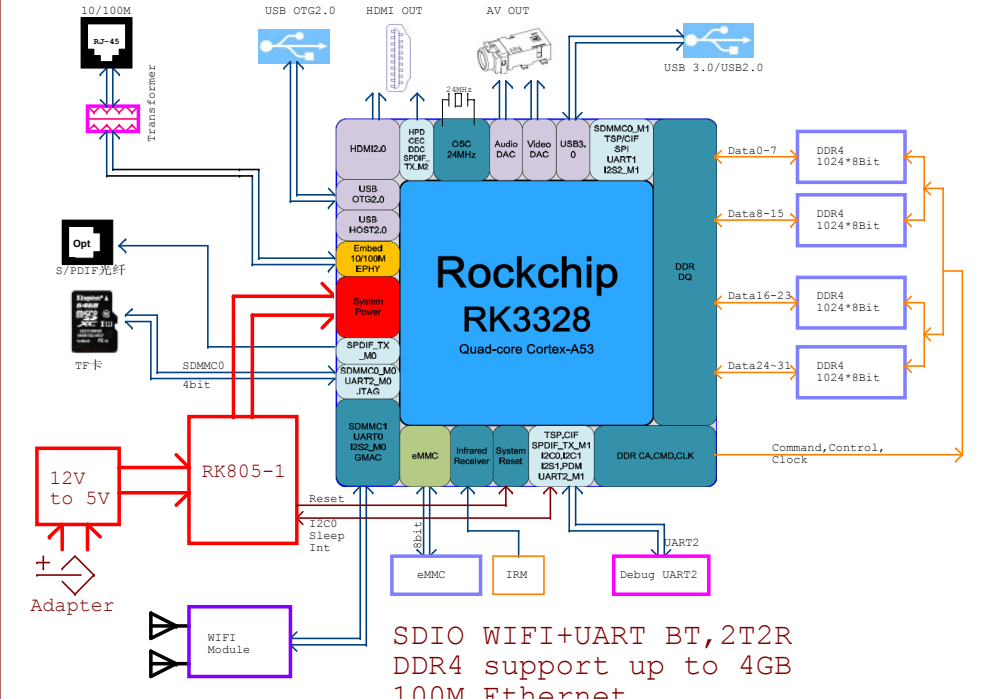

Config4

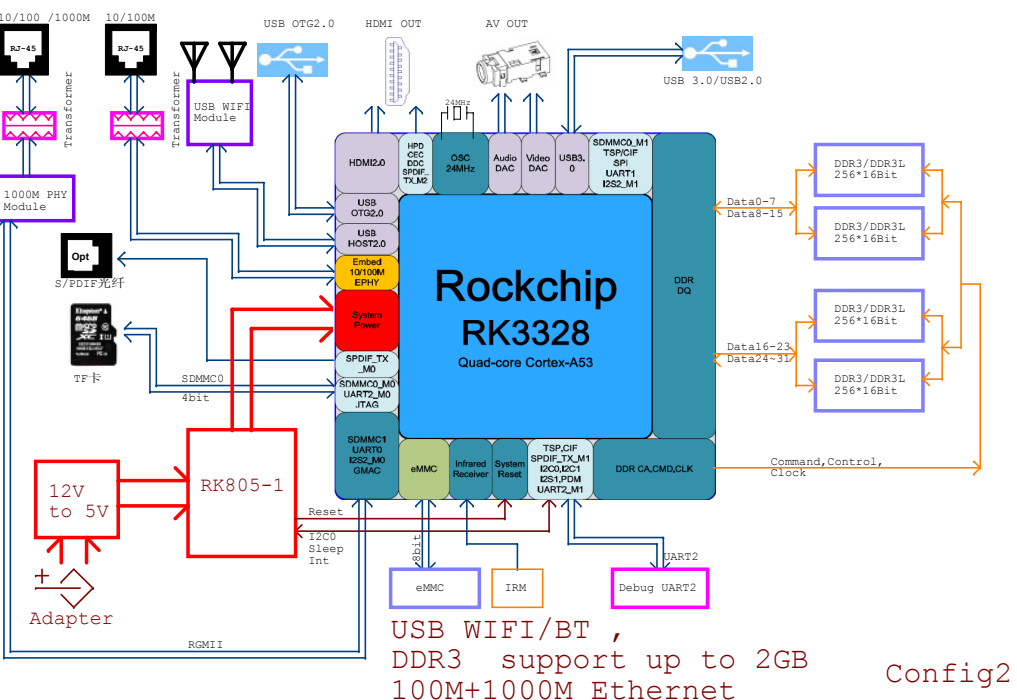

Config2

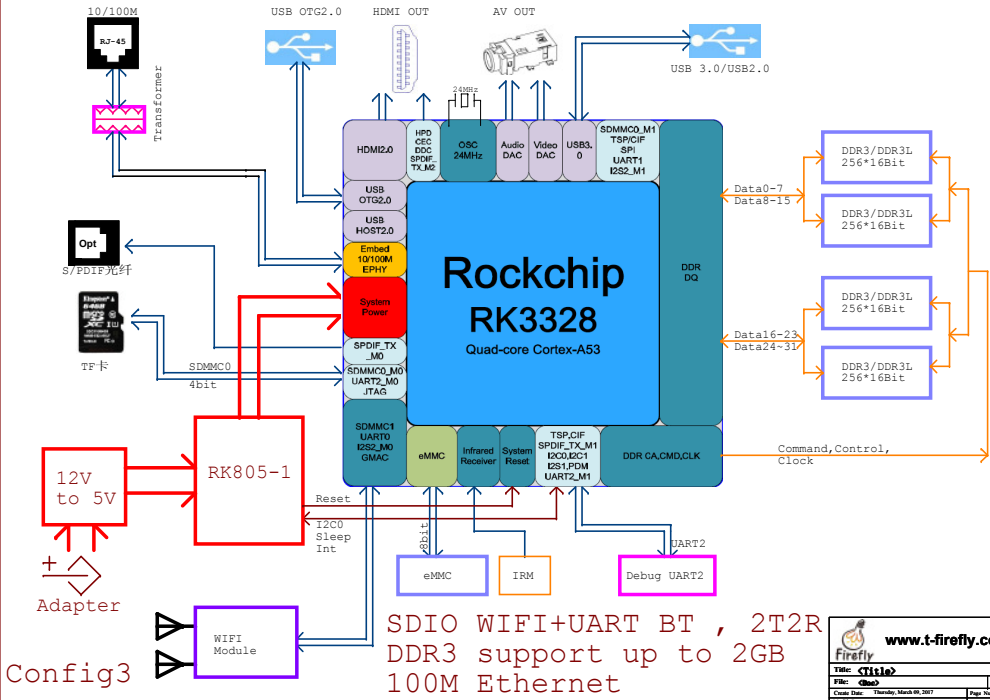

Config3

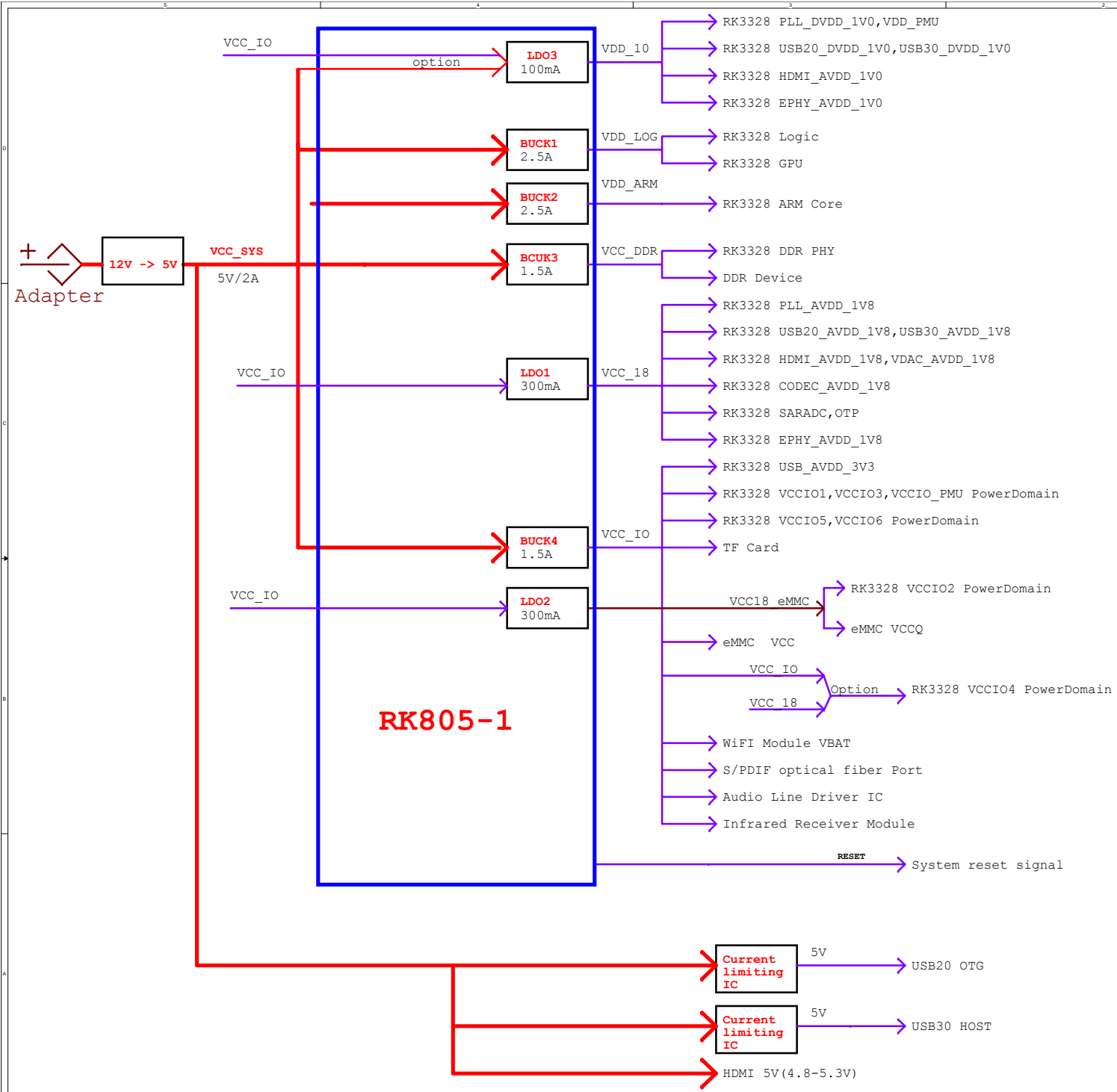

Power Timing

TYPE	VOLT	STEP	PowerName
BUCK1	1.1V		VDD_LOG
BUCK2	1.1V		VDD_ARM
BUCK3	FB=0.8V		VCC_DDR
BUCK4	3.3V		VCC_IO
LDO1	1.8V		VCC_18
LDO2	1.8V		VCC18_eMMC
LDO3	1.0V		VDD_10

IR

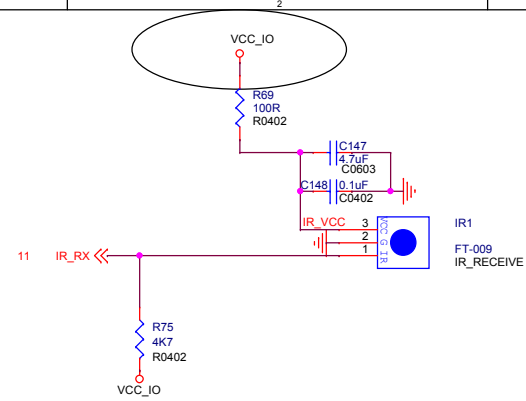

IR1
FT-009
IR_RECEIVE

LED DISPLAY

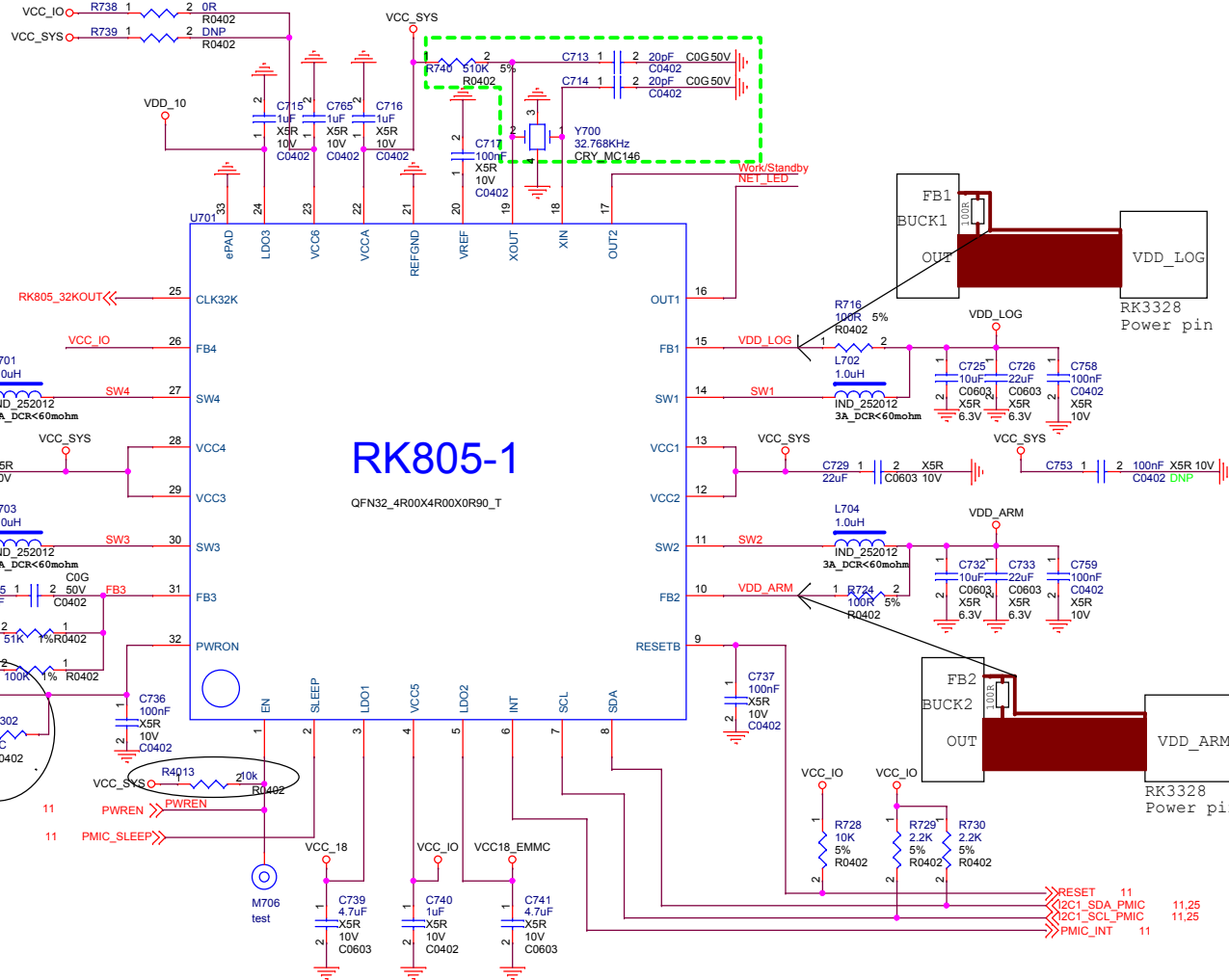
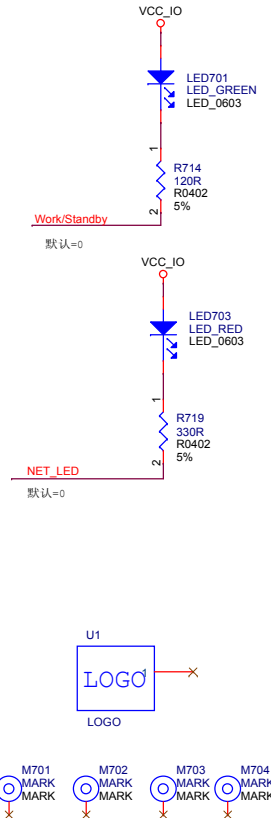

RK805-1

QFN32_4R00X4R00X0R90_T

Default:DDR3=1.5V

	DDR3	DDR3L	DDR4
VCC_DDR	1.527V	1.353V	1.2V
R725	100K 1%	47K 1%	51K 1%
R726	110K 1%	68K 1%	100K 1%

VCC_DDR

www.t-firefly.com

Title: <Title>
 File: <Doc> REV: <Revcode>
 Create Date: Thursday, March 09, 2017 Page Num: 5
 Modify Date: Monday, December 11, 2017 Page Total: 25

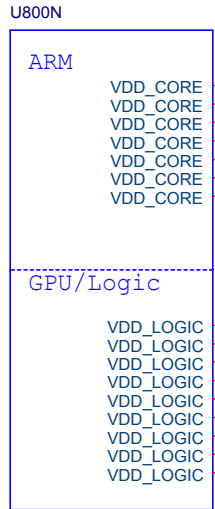

RK3328
BGA395_14R00X14R00X1R24

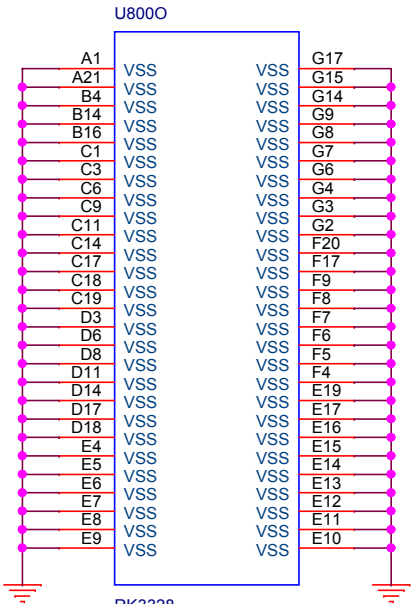

RK3328
BGA395_14R00X14R00X1R24

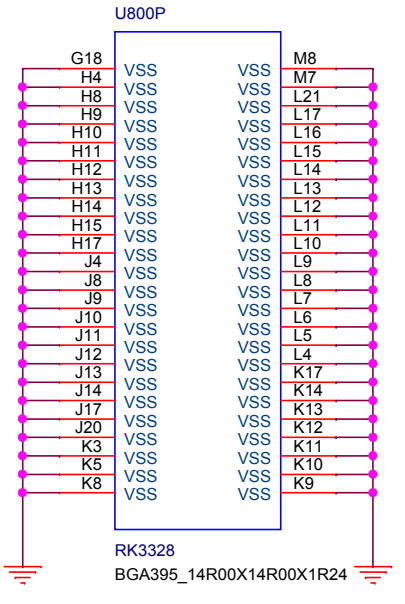

RK3328
BGA395_14R00X14R00X1R24

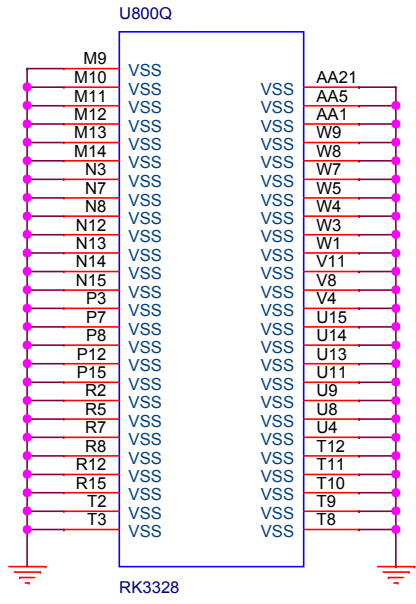

RK3328
BGA395_14R00X14R00X1R24



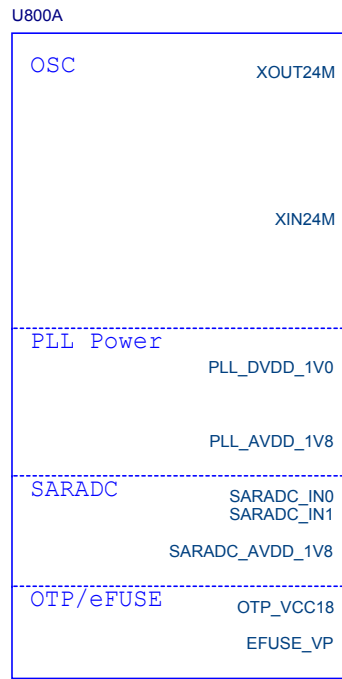

www.t-firefly.com

Title: <Title>
File: <Doc> REV: <Revcode>
Create Date: Thursday, March 09, 2017 Page Num: 6
Modify Date: Monday, December 11, 2017 Page Total: 25



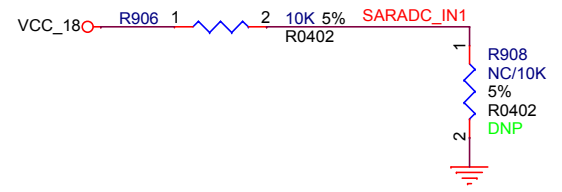
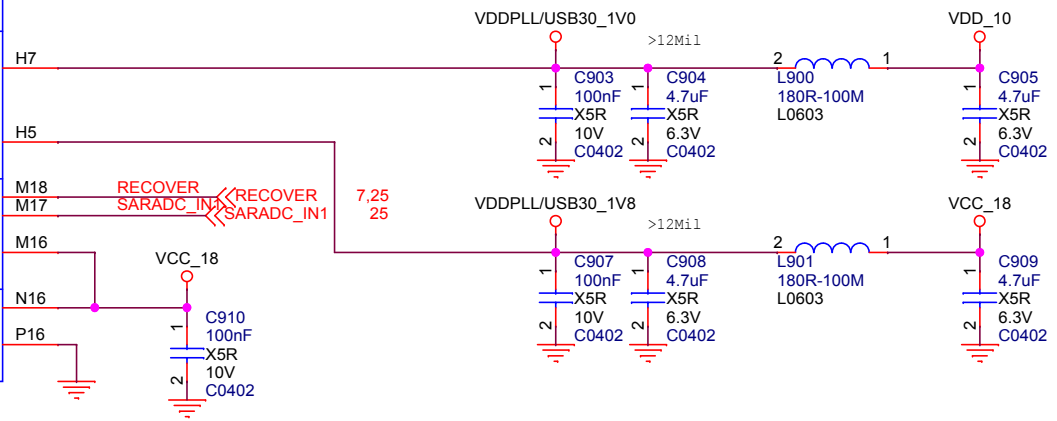
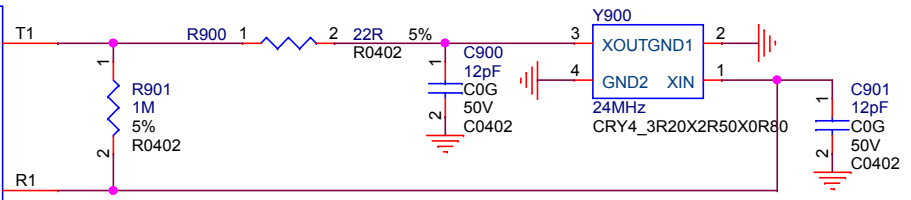

RK3328
BGA395_14R00X14R00X1R24

www.t-firefly.com

Title: <Title>	
File: <Doc>	REV: <Revcode>
Create Date: Thursday, March 09, 2017	Page Num: 7
Modify Date: Monday, December 11, 2017	Page Total: 25

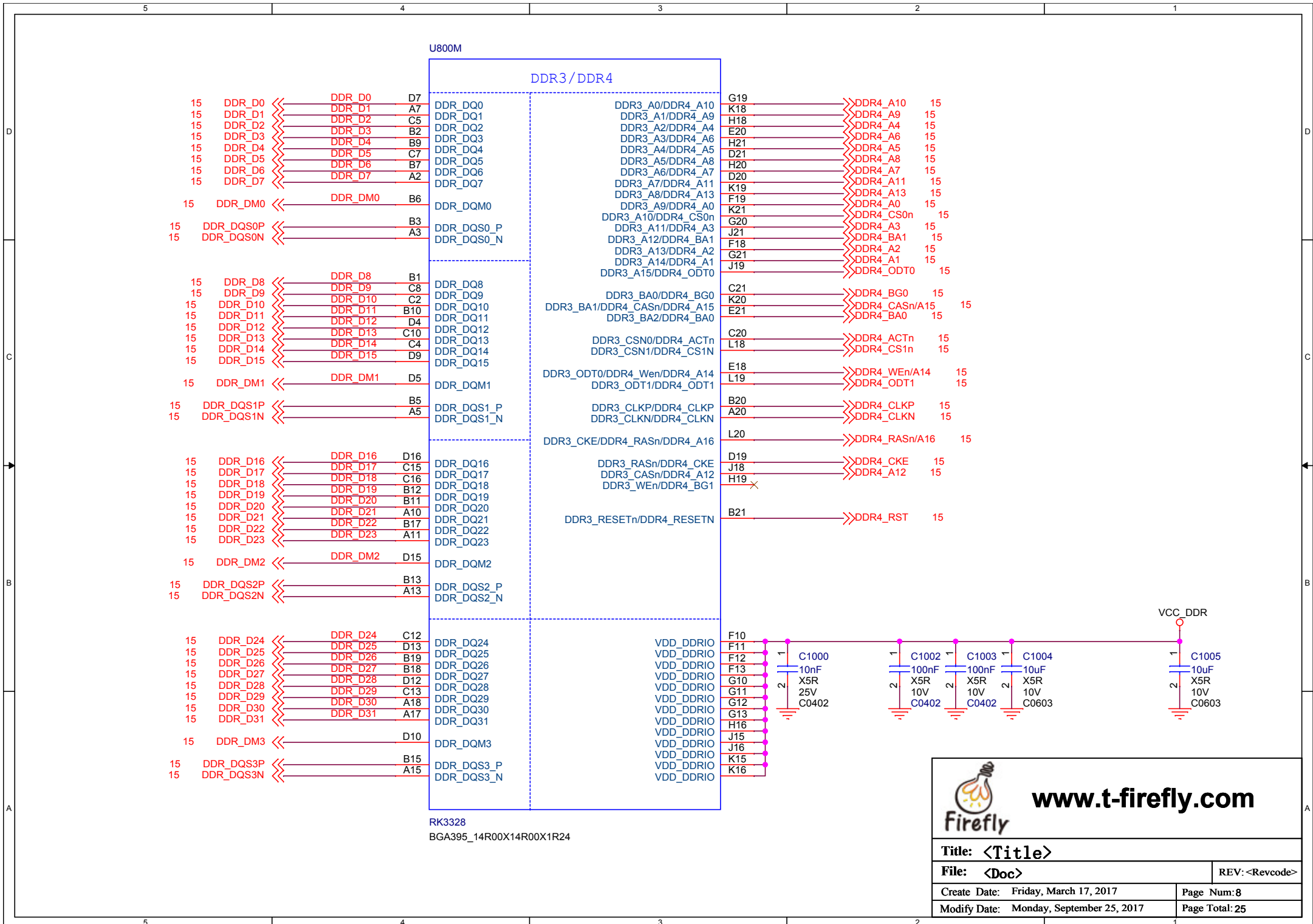

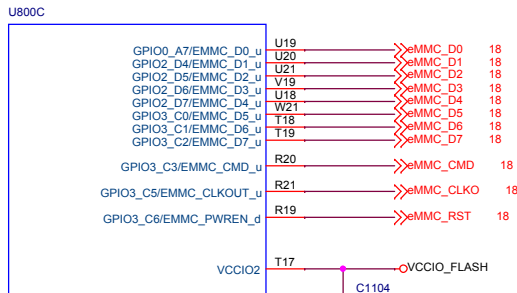

www.t-firefly.com

Title: <Title>	
File: <Doc>	REV: <Revcode>
Create Date: Friday, March 17, 2017	Page Num: 8
Modify Date: Monday, September 25, 2017	Page Total: 25

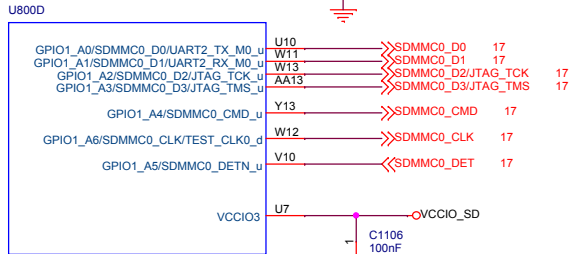

RK3328
BGA395_14R00X14R00X1R24



RK3328
BGA395_14R00X14R00X1R24

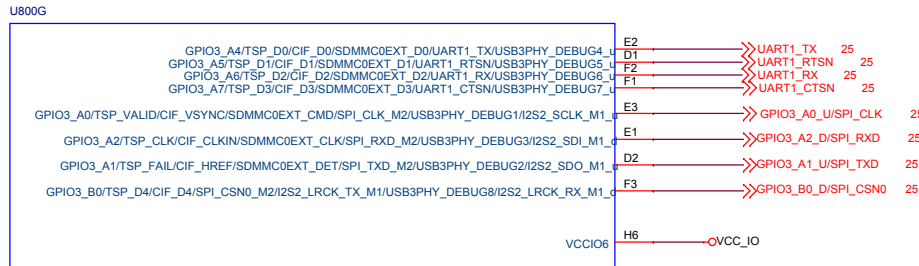

RK3328
BGA395_14R00X14R00X1R24

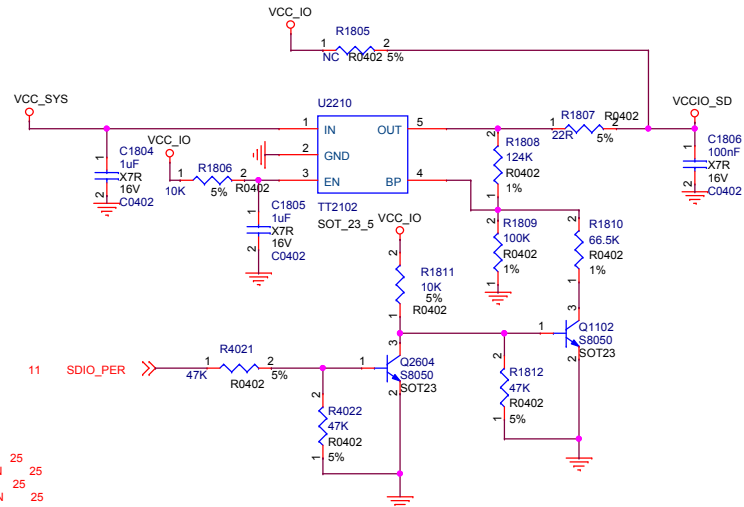

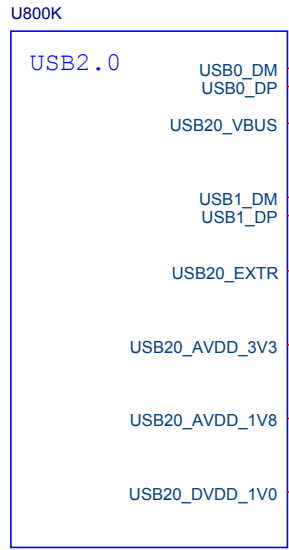



RK3328
 BGA395_14R00X14R00X1R24

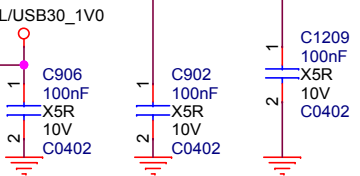
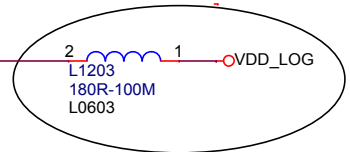
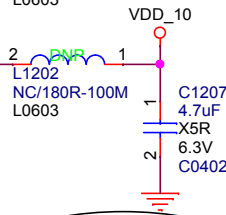
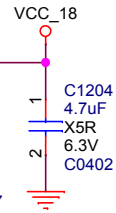
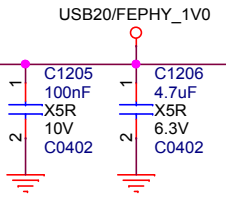
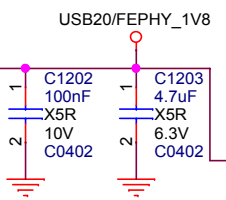
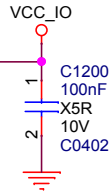
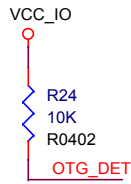

RK3328
 BGA395_14R00X14R00X1R24

www.t-firefly.com

Title: <Title>		REV: <Revcode>
File: <Doc>		
Create Date: Thursday, March 09, 2017	Page Num: 10	
Modify Date: Monday, September 25, 2017	Page Total: 25	

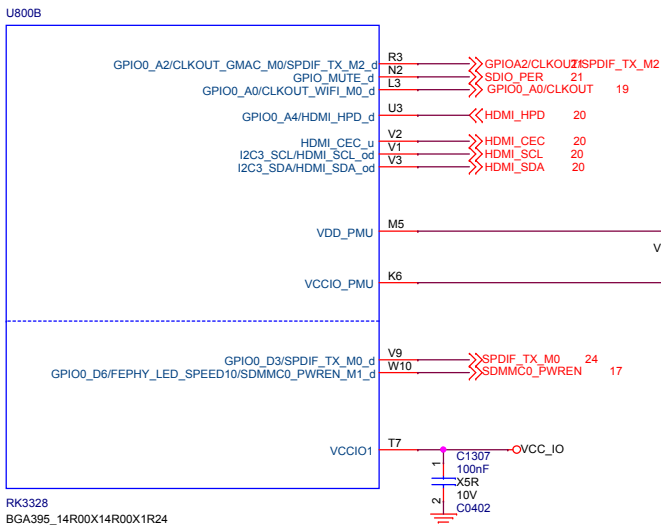
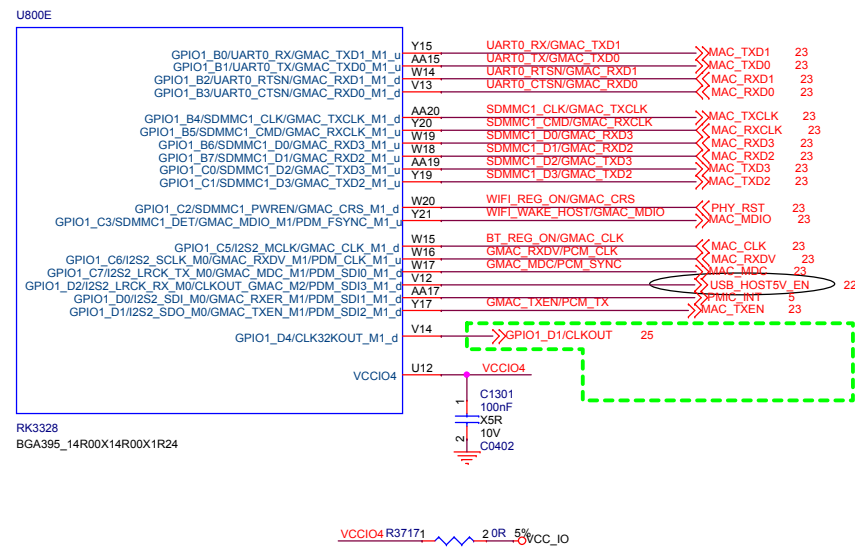
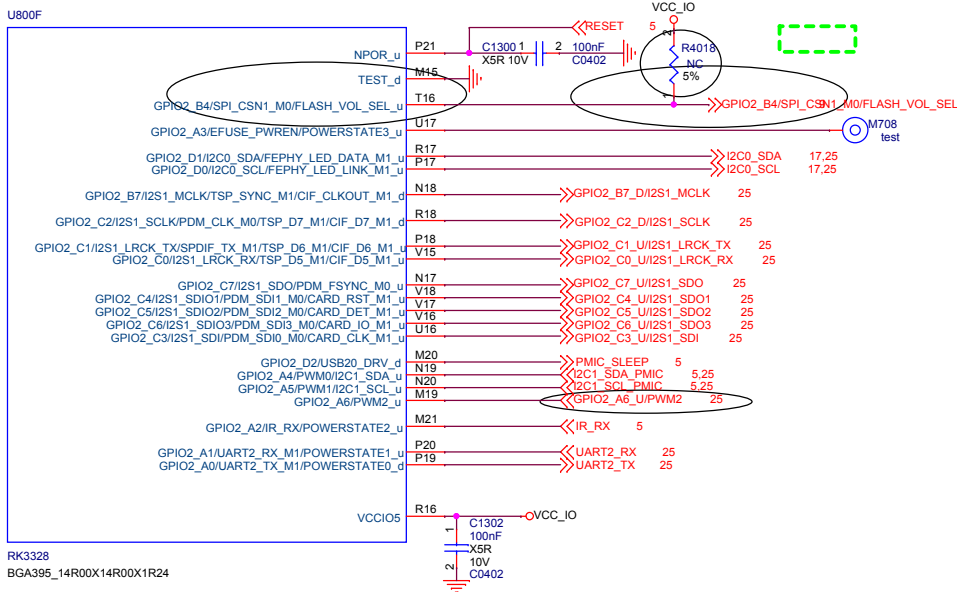

Firefly
www.t-firefly.com

Title: <Title>
File: <Doc> REV: <Revcode>
Create Date: Thursday, March 09, 2017 Page Num: 11
Modify Date: Monday, December 11, 2017 Page Total: 25

U8001



RK3328
BGA395_14R00X14R00X1R24

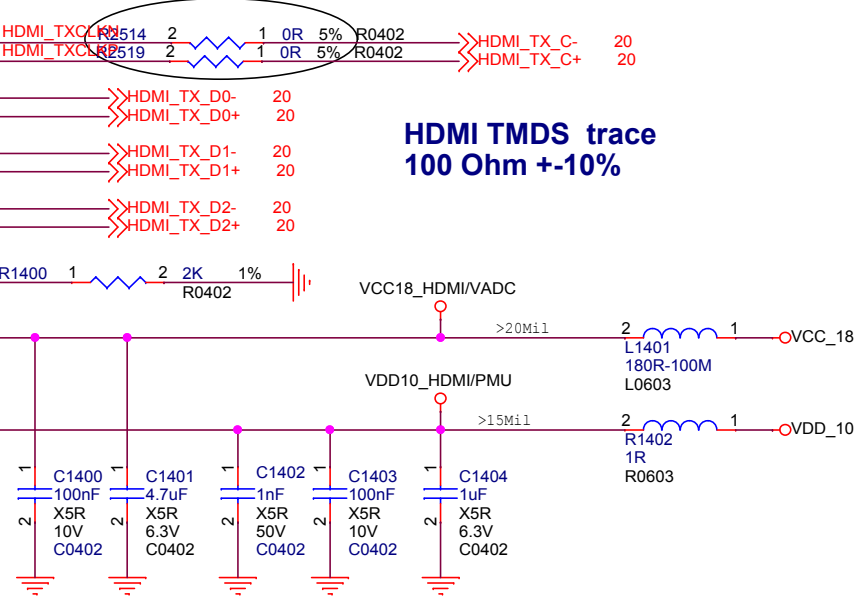



**HDMI TMS trace
100 Ohm +-10%**

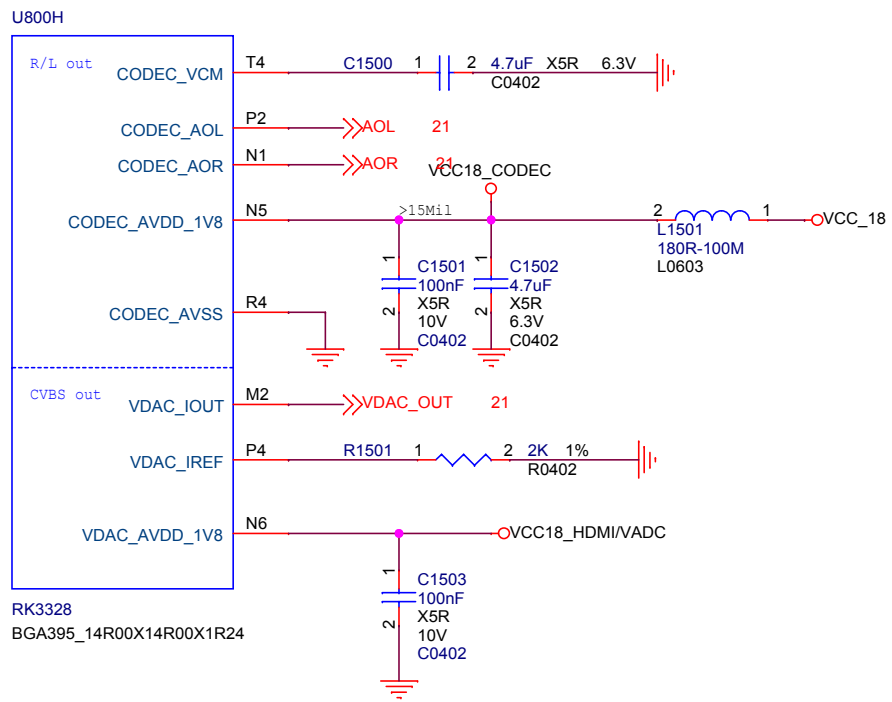

www.t-firefly.com

Title: <Title>	
File: <Doc>	REV: <Revcode>
Create Date: Thursday, March 09, 2017	Page Num: 12
Modify Date: Monday, September 25, 2017	Page Total: 25



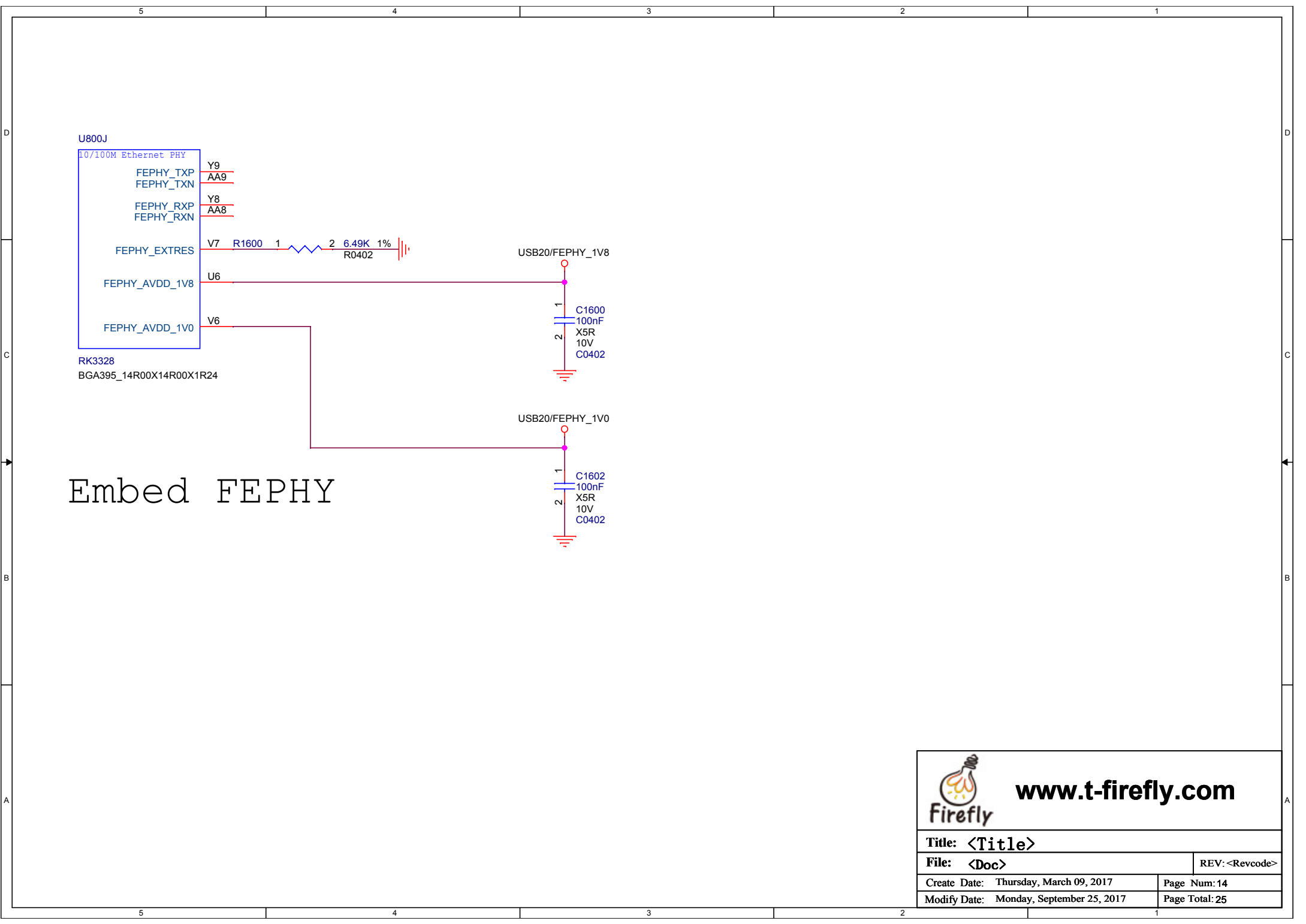

www.t-firefly.com

Title: <Title>	
File: <Doc>	REV: <Revcode>
Create Date: Thursday, March 09, 2017	Page Num: 13
Modify Date: Monday, September 25, 2017	Page Total: 25



Embed FEPHY

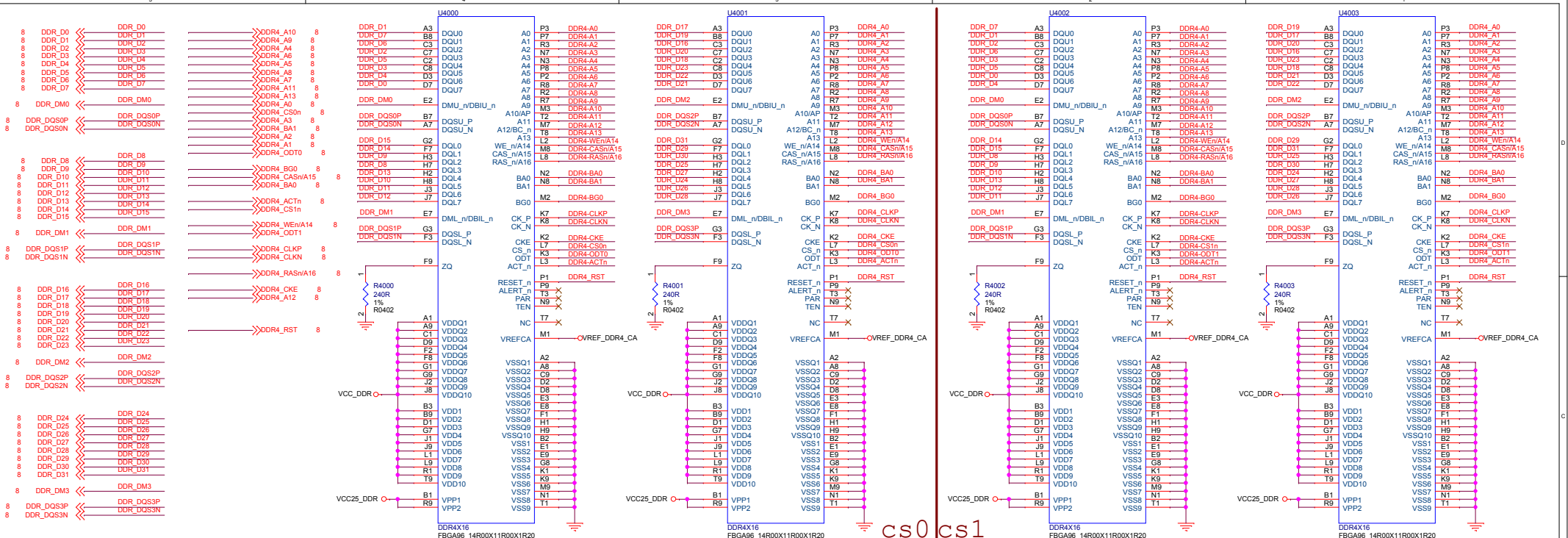

www.t-firefly.com

Title: <Title>	
File: <Doc>	REV: <Revcode>
Create Date: Thursday, March 09, 2017	Page Num: 14
Modify Date: Monday, September 25, 2017	Page Total: 25

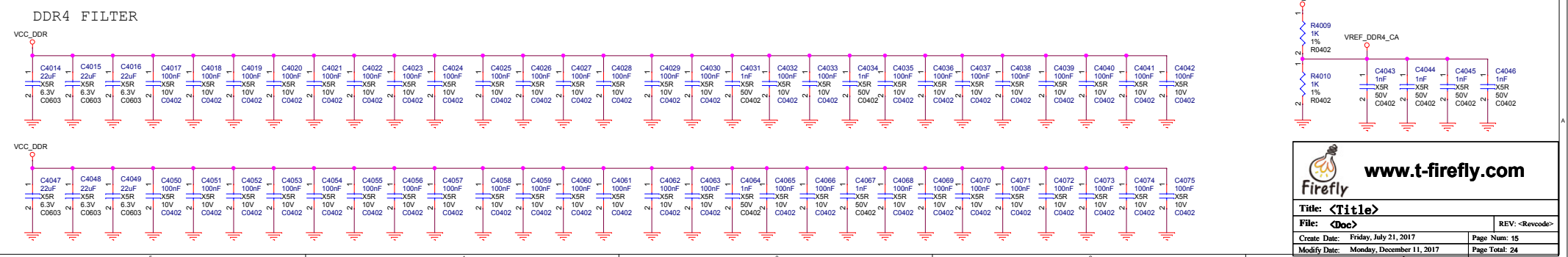
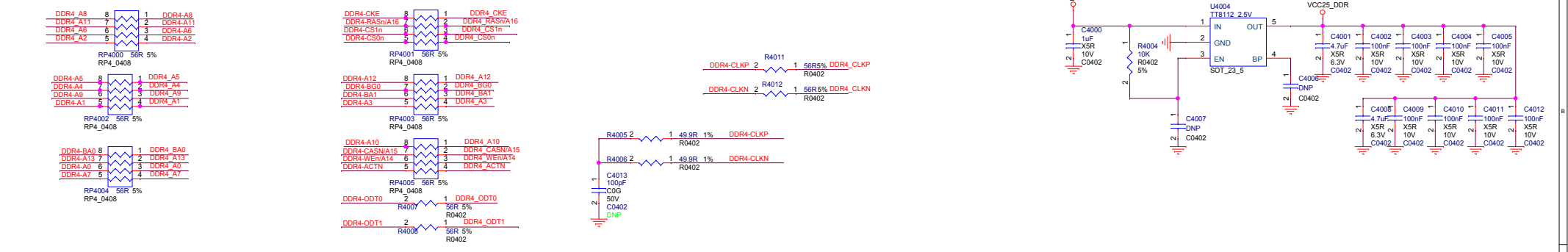

4X16bit DDR4



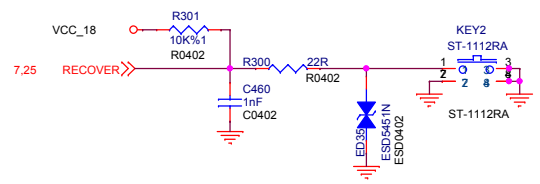
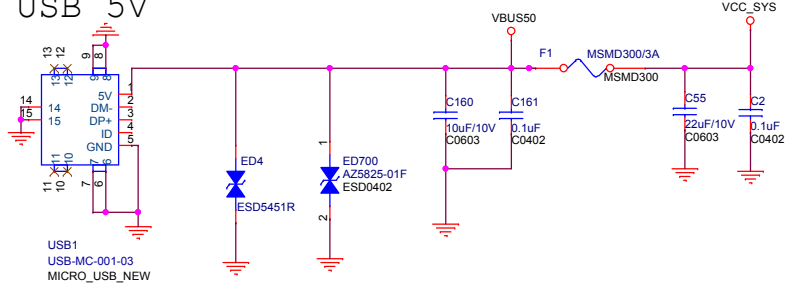

www.t-firefly.com
Title: <Title>
File: <Doc>
REV: <Revcode>
Create Date: Friday, July 21, 2017 **Page Num:** 15
Modify Date: Monday, December 11, 2017 **Page Total:** 24

USB 5V

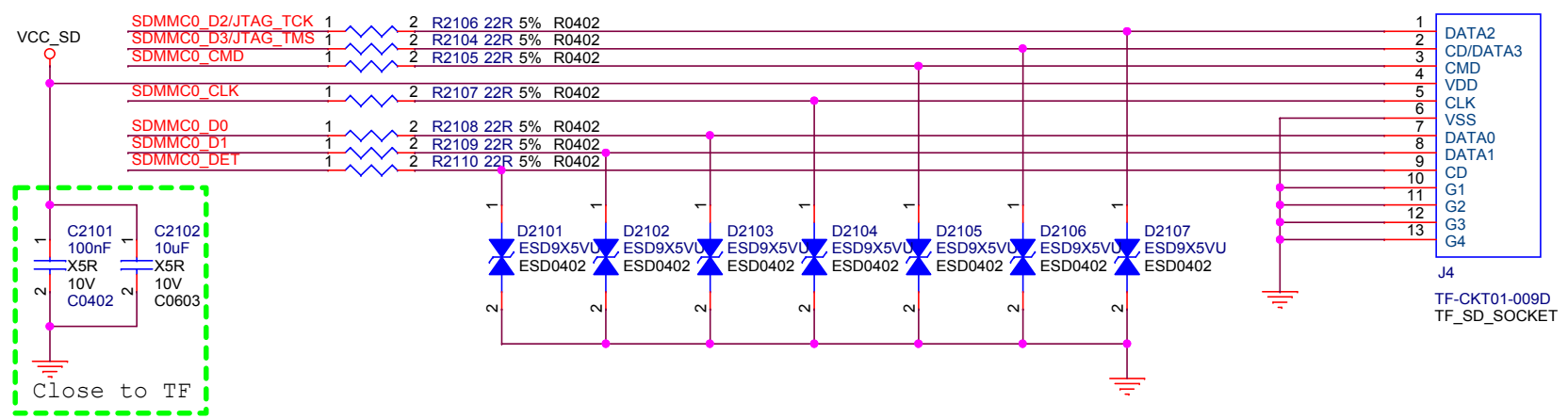
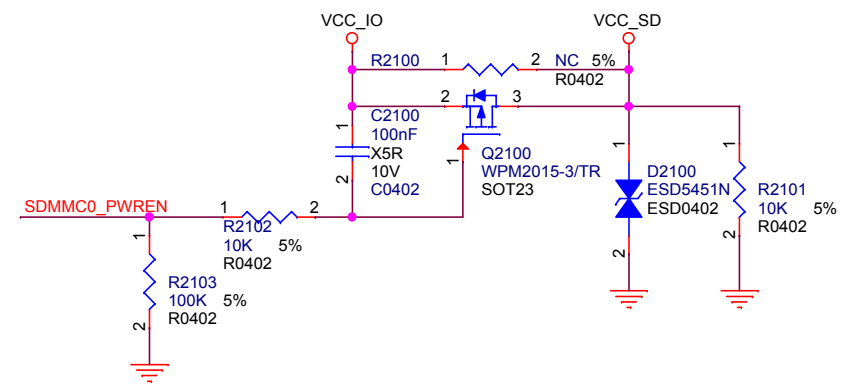
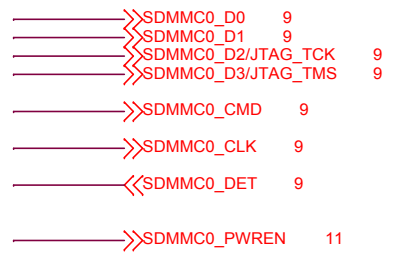

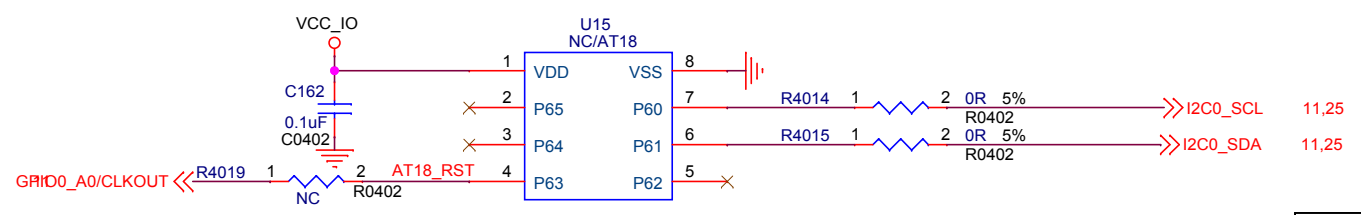

AT18



www.t-firefly.com

Title: <Title>
 File: <Doc> REV: <Revcode>
 Create Date: Thursday, March 09, 2017 Page Num: 17
 Modify Date: Monday, September 25, 2017 Page Total: 24

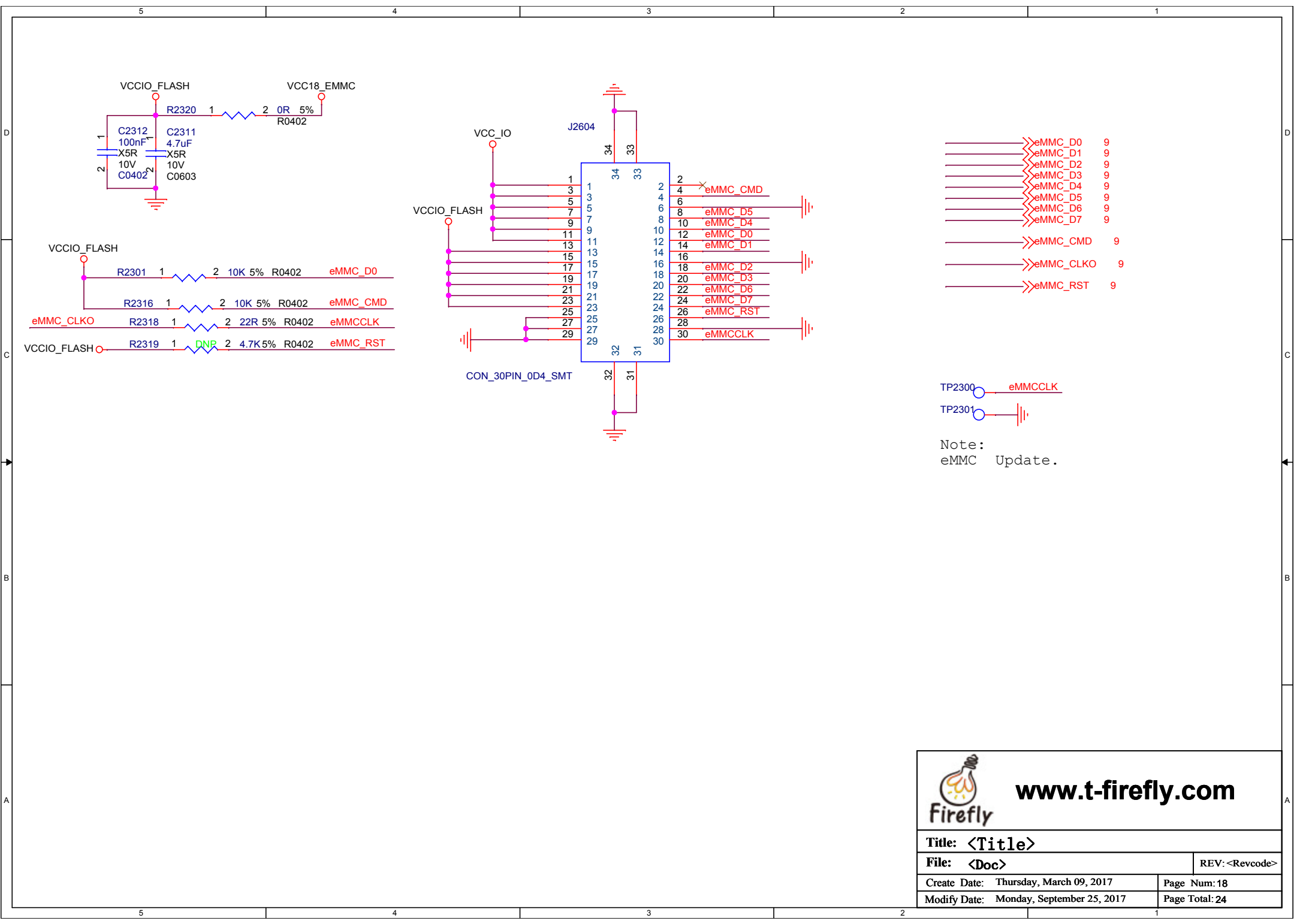

- >>eMMC_D0 9
- >>eMMC_D1 9
- >>eMMC_D2 9
- >>eMMC_D3 9
- >>eMMC_D4 9
- >>eMMC_D5 9
- >>eMMC_D6 9
- >>eMMC_D7 9
- >>eMMC_CMD 9
- >>eMMC_CLKO 9
- >>eMMC_RST 9

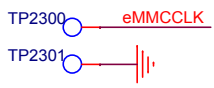

Note:
eMMC Update.



www.t-firefly.com

Title: <Title>	
File: <Doc>	REV: <Revcode>
Create Date: Thursday, March 09, 2017	Page Num: 18
Modify Date: Monday, September 25, 2017	Page Total: 24

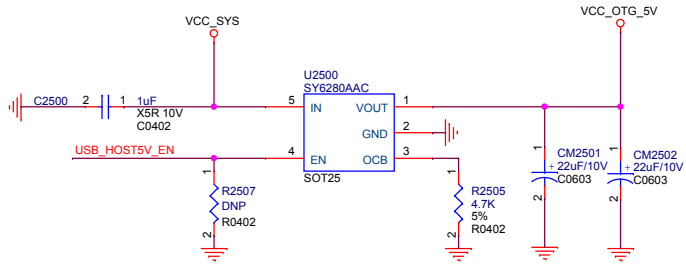

- >>>USB20_HOST_DM 10
- >>>USB20_HOST_DP 10
- >>>OTG20_DM 10
- >>>OTG20_DP 10
- >>>USB_HOST5V_EN 11
- >>>OTG_DET 10

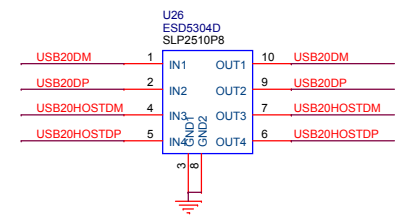
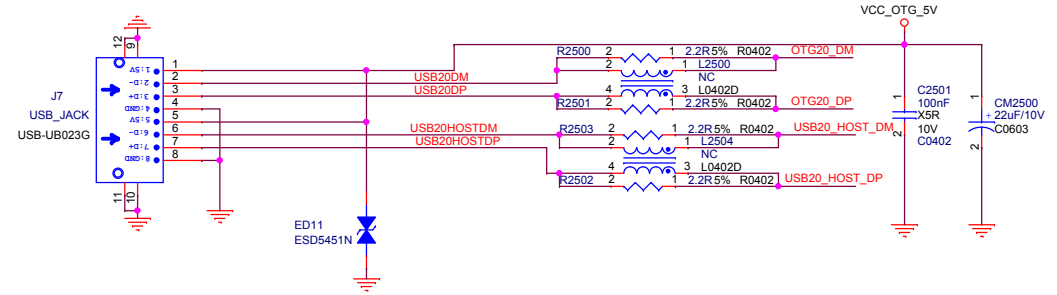

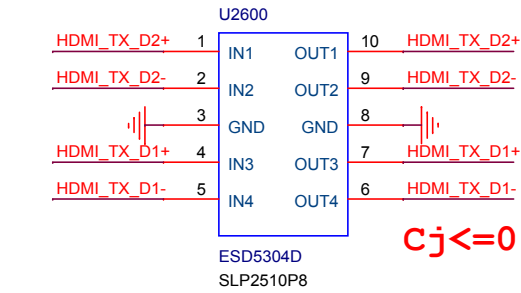
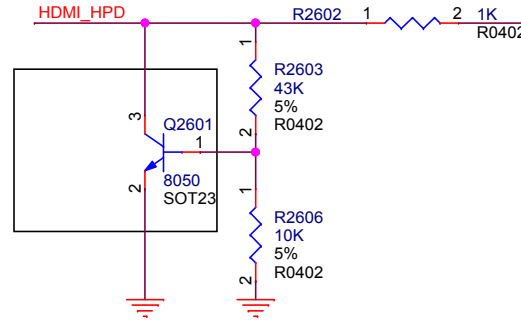
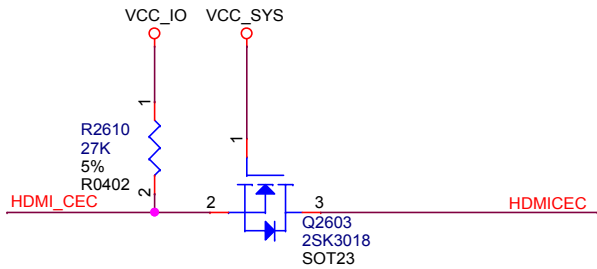
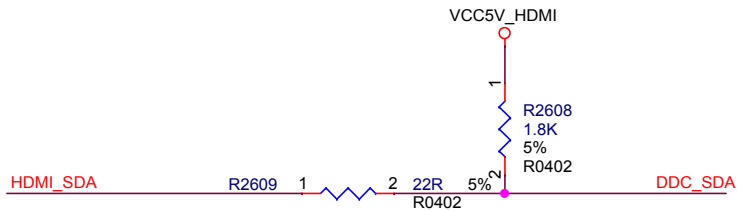
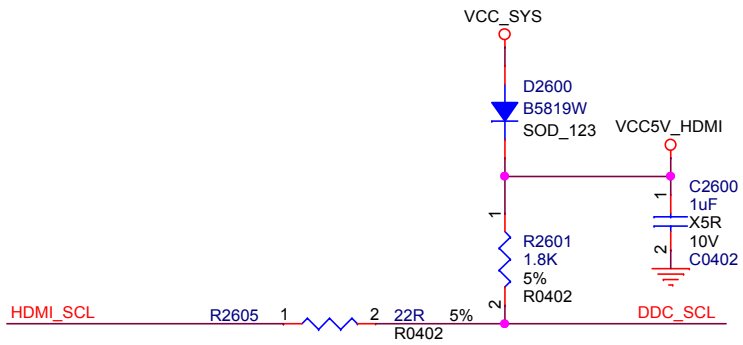

Cj <= 0.4pF

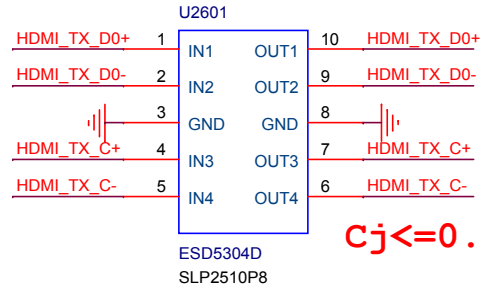

Cj <= 0.4pF

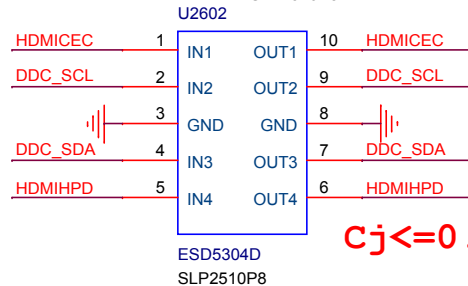

Cj <= 0.4pF

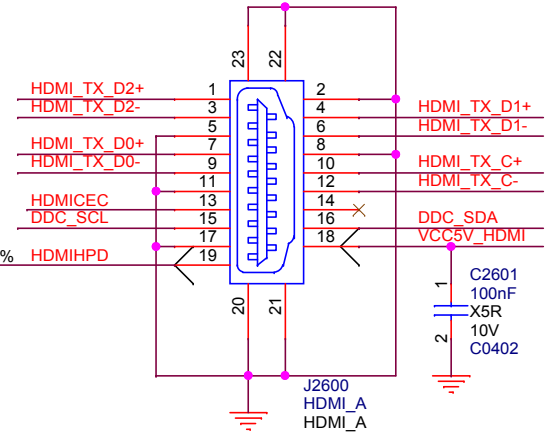

HDMI OUT

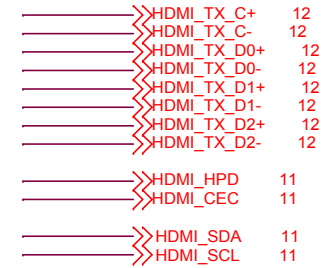



www.t-firefly.com

Title: <Title>		REV: <Revcode>	
File: <Doc>			
Create Date: Thursday, March 09, 2017	Page Num: 20		
Modify Date: Monday, September 25, 2017	Page Total: 24		

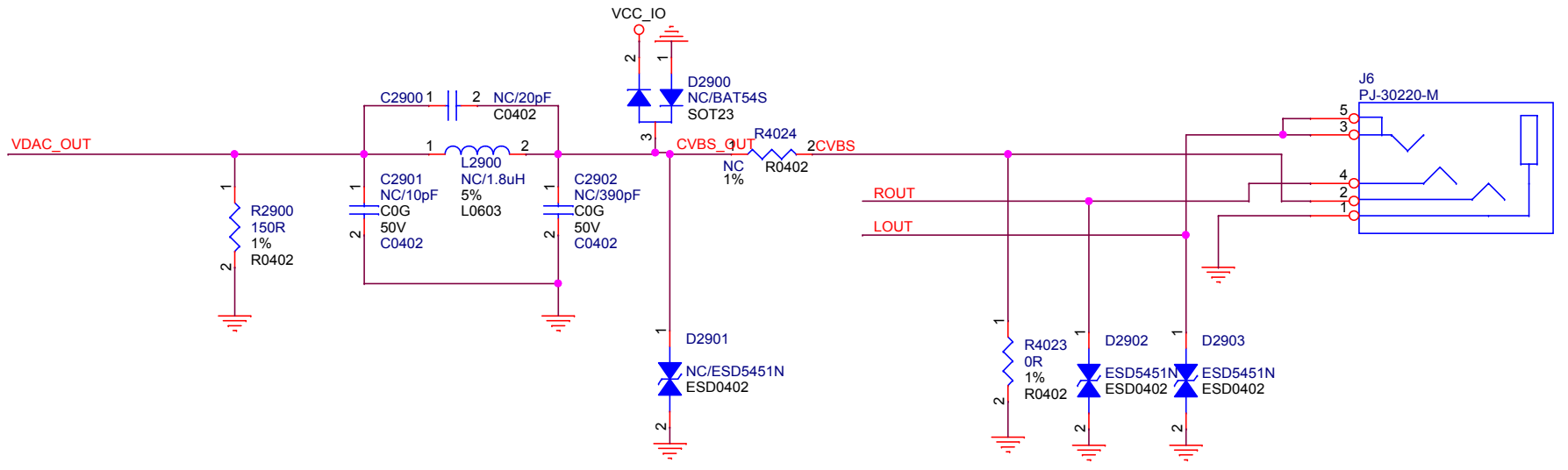

AV OUT

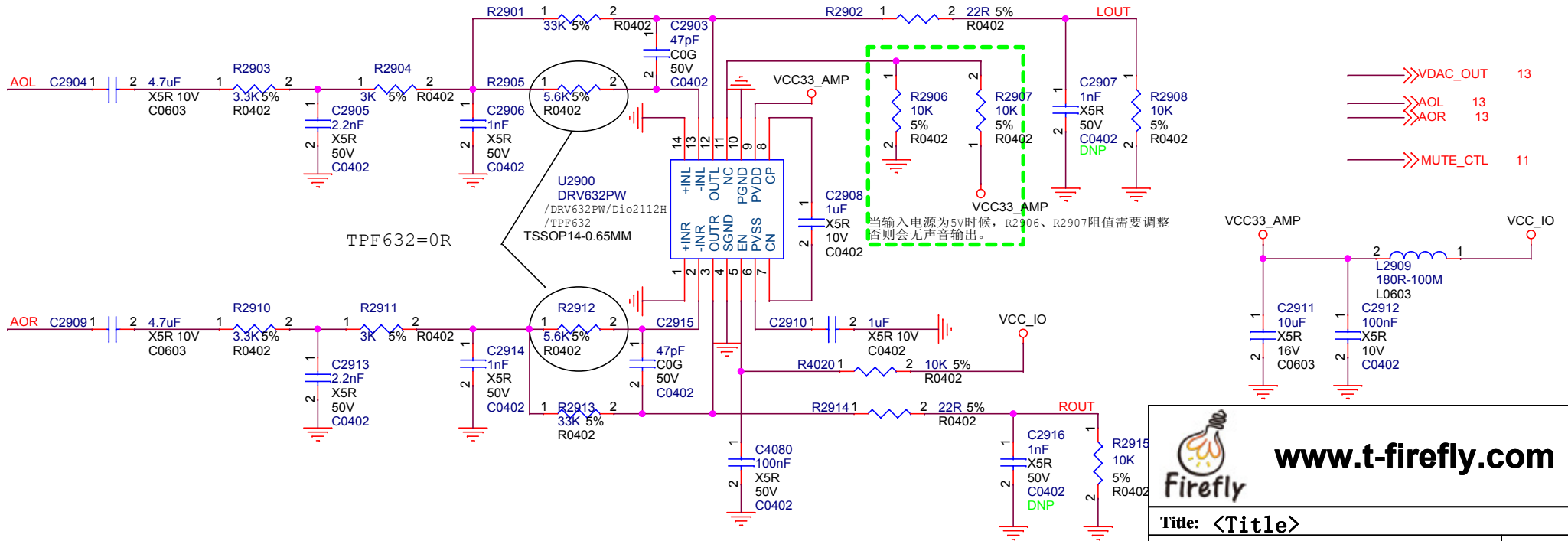

- >>>VDAC_OUT 13
- >>>AOL 13
- >>>AOR 13
- >>>MUTE_CTL 11

2-Vrms Audio Line Driver



www.t-firefly.com

Title: <Title>		REV: <Revcode>
File: <Doc>		
Create Date: Thursday, March 09, 2017	Page Num: 21	
Modify Date: Monday, September 25, 2017	Page Total: 24	

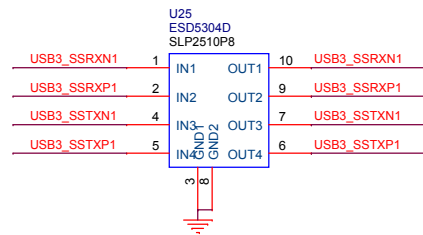
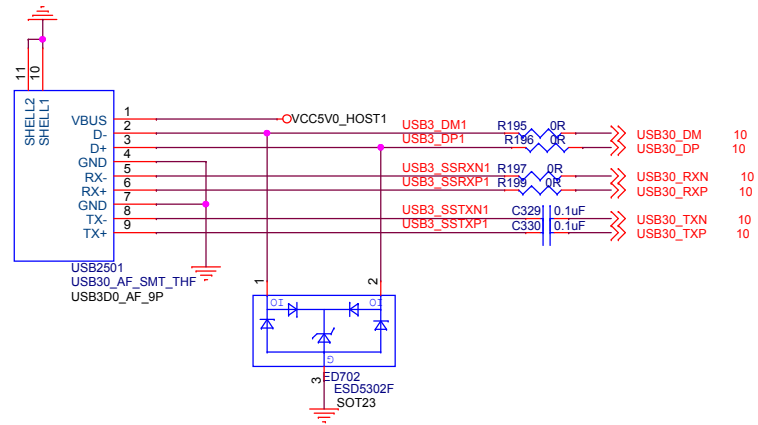
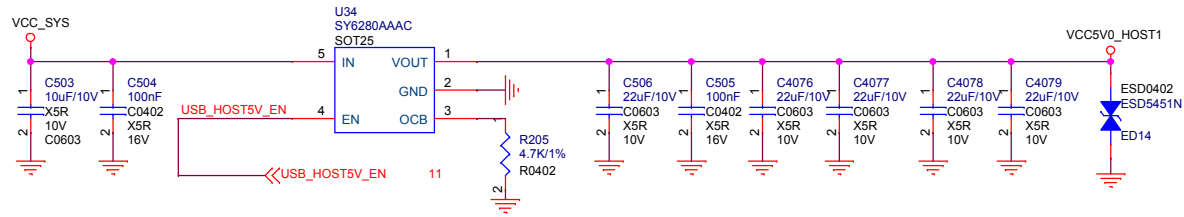

		www.t-firefly.com	
Title: <Title>			
File: <Doc>		REV: <Revcode>	
Create Date: Tuesday, May 16, 2017	Page Num: 22		
Modify Date: Monday, September 25, 2017	Page Total: 24		

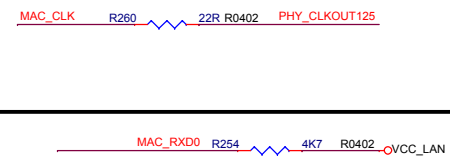
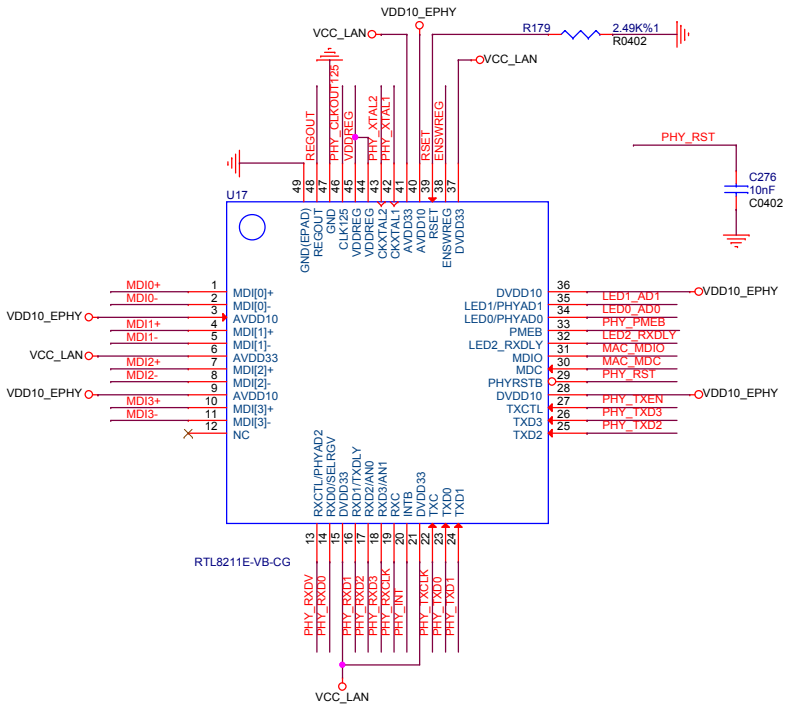
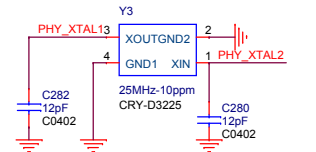
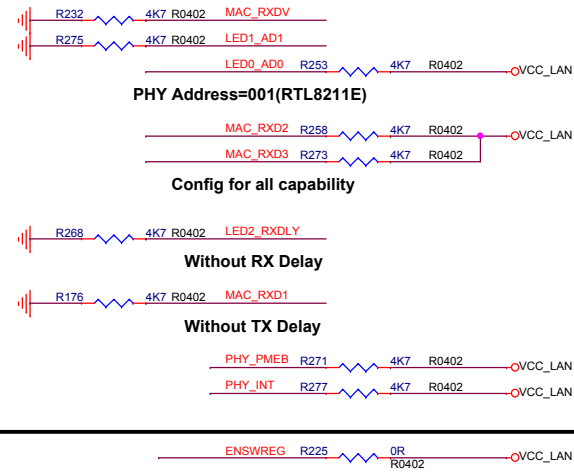
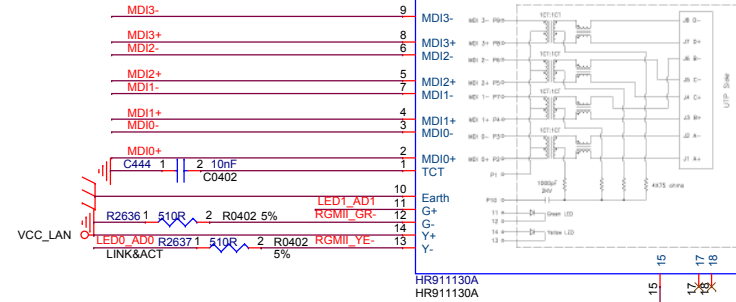
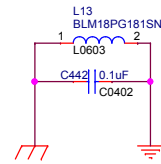
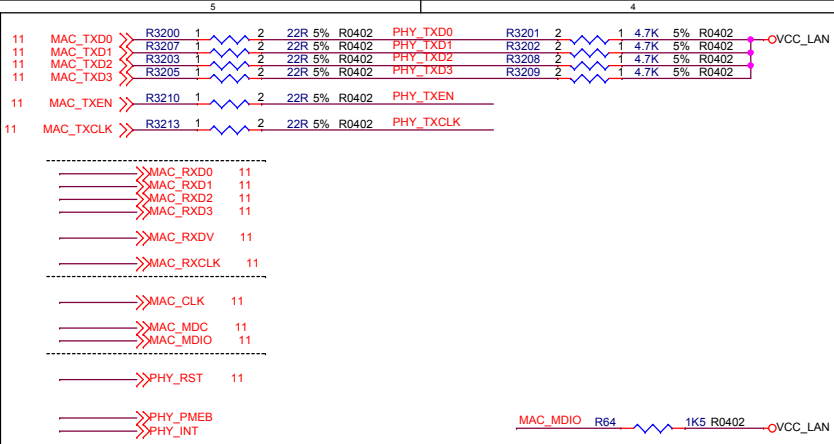

Connect ENSWREG to AVDD33 to enable Switching regulator or connect ENSWREG to GND to disable Switching regulator.

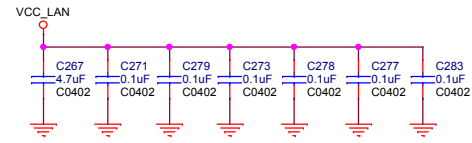
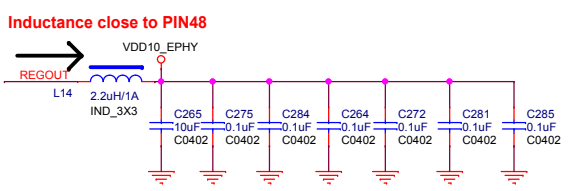

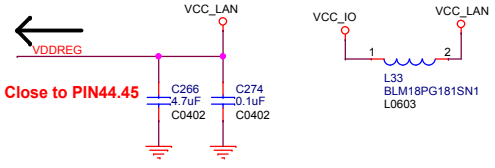
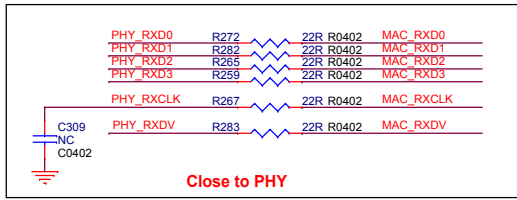

Pull down for 2.5V RGMII(RTL8211D/8211E)
 Pull up for 3.3V RGMII (RTL8211D/8211E)
 Pull up 1.5 /1.8V RGMII (RTL8211E-VL only)

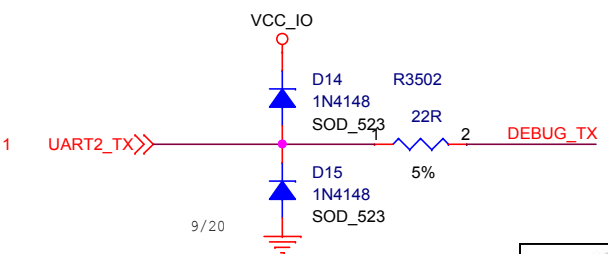
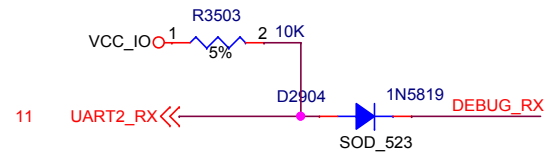
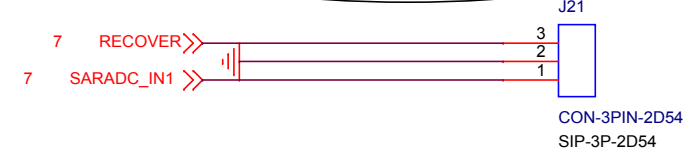
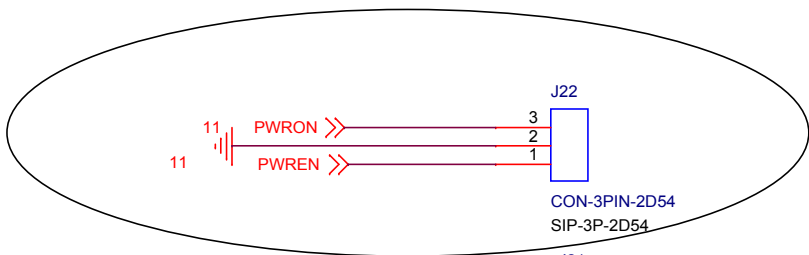
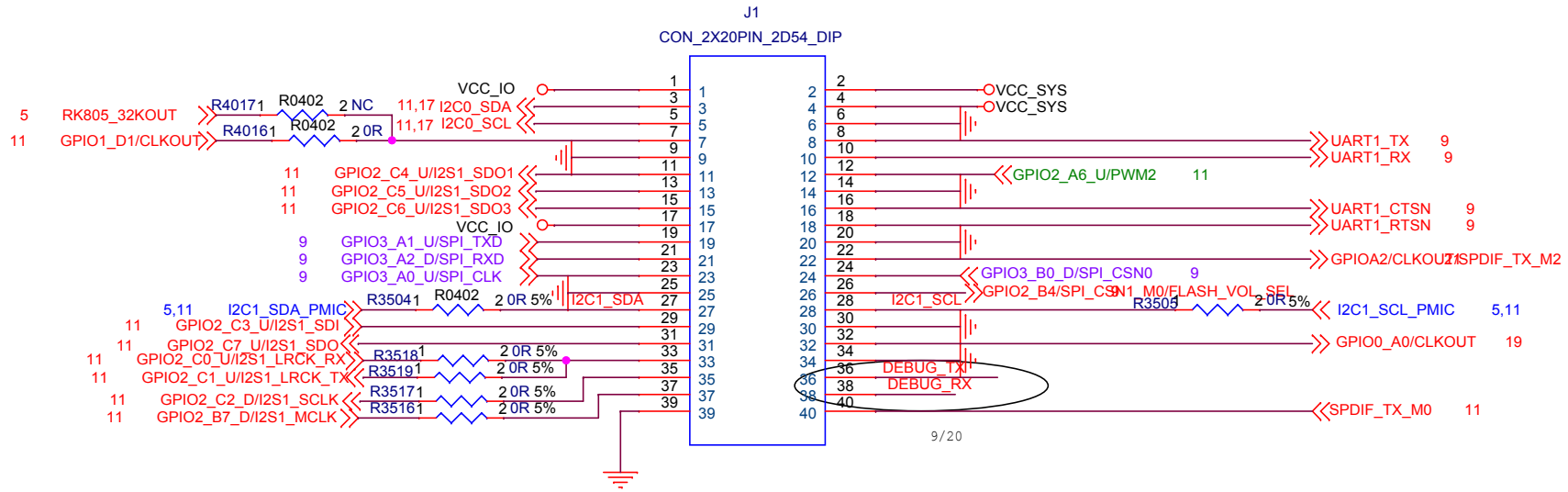

www.t-firefly.com

Title: <Title>
 File: <Doc> REV: <Revcode>
 Create Date: Friday, July 28, 2017 Page Num: 23
 Modify Date: Monday, September 25, 2017 Page Total: 24





www.t-firefly.com

Title: <Title>	
File: <Doc>	REV: <Revcode>
Create Date: Friday, March 17, 2017	Page Num: 24
Modify Date: Monday, December 11, 2017	Page Total: 24